

1 Information Brochure Choose controls to match application	2 Application Brochure Design your mechanical applications	3 Rough In Wiring Rough-in wiring instructions	4 Wiring Brochure Wiring and installation of specific control	5 Data Brochure Control settings and sequence of operation	6 Job Record Record settings & wiring details for future reference
---	--	--	---	--	--

Introduction

The User Switch 481 has 3 programmable buttons that allow users to easily change the operating scene or allow users to enable/disable tN4 setpoint controls on a tN4 system.

Multiple User Switches are required if more than 3 scenes or setpoint enable / disables are desired.

The 481 has 3 output relay contacts that allow for connection to alarm systems or paging systems to alert service personnel. The output relay contacts can also be used to indicate the scene of the tN4 system to an automation system.

Features

- tN4 Compatible
- 3 User buttons
- 3 Programmable Output Relay Contacts
 - Output for Critical Alert
 - Output for Non Critical Alert
 - Output for Scenes
 - Output for Enable / Disable Signal

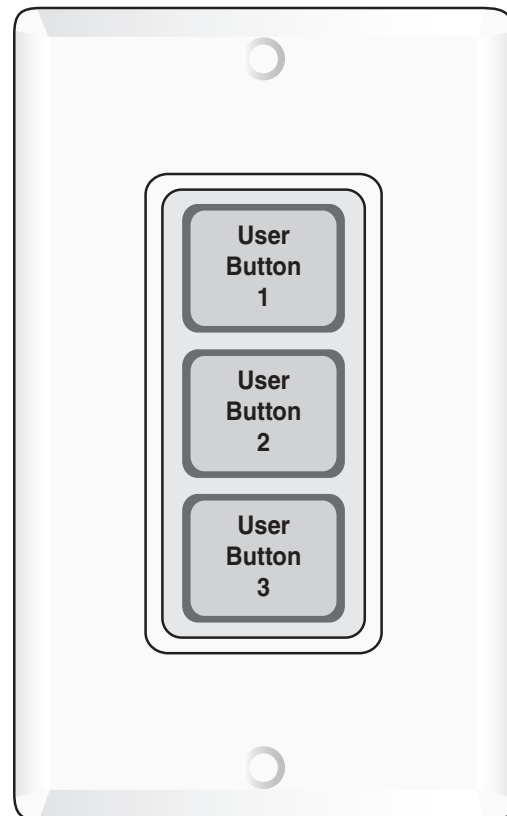

Decora cover plate not included

Table of Contents

Table of Contents.....	2	Applications Using Multiple 480 & 481 Together	7
User Interface.....	2	Error Messages	7
Sequence of Operation.....	3	Cleaning the User Switch	8
3 User Buttons	3	User Button Label Template	8
Programming the User Buttons	4	Warranty	8
Output Relay Contacts and DIP Switches	6		

User Interface

The User Switch has a total of 5 buttons.

User Buttons 1, 2, and 3 allow for users to select the operation of the tN4 system.

Buttons A and B allow the installer to program the operation of User Buttons 1, 2, and 3.

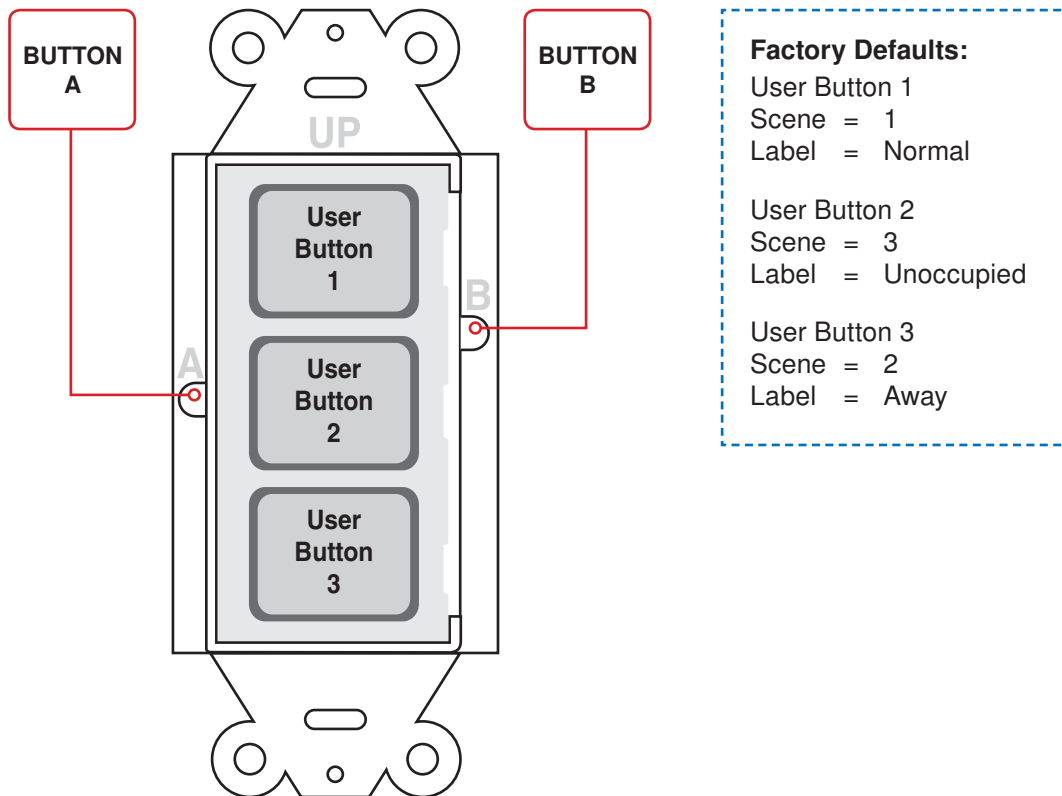

Sequence of Operation

Three User Buttons

The User Switch provides users with a simple interface to change the operating scene of the tN4 system or provide an enable/disable to tN4 setpoint controls. The 481 has 3 User Buttons and 3 output relay contacts.

The 3 User Buttons provide the ability to:

1) Select a scene for the tN4 system

The User Buttons allow users to select the scene of the tN4 system. Each of the 3 User Buttons is programmed by the installer to select a particular scene on the tN4 system. The temperature of each tN4 thermostat in the system is pre-programmed by the installer for each of the scenes. This allows users to change the temperature of all the thermostats using a single button.

tN4 thermostats and tN4 setpoint controls must have Scenes turned to "On" in order to respond to scene changes on the User Switch.

When a User Button is pressed, the green LED under that button turns on and remains on until a new scene is selected, or the time for the selected temporary scene expires.

When the current selected scene on the tN4 network is the same as the scene that the User Button is programmed for, the button turns green.

When a selected scene is "On" and that User Button is pressed again, the scene is changed based on the following table:

Current Scene	Press the Same Button	New Scene
Perm Scene 1	→	No Change
Perm Scene 2 - Away	→	Selects Scene 1
Perm Scene 3 - Unoccupied	→	Selects Scene 1
Perm Scene 4	→	Selects Scene 1
Perm Scene 5	→	Selects Scene 1
Tmpy Scene 6 - Occupied	→	Selects previous perm scene
Tmpy Scene 7	→	Selects previous perm scene
Tmpy Scene 8	→	Selects previous perm scene

Application Examples:

Allows residential users to change the scene to 2 (Away) while going on vacation, or select an occupied scene while entertaining guests.

Allows commercial users a simple way to allow staff to override the night setback / setup schedule on the tN4 system.

2) Provide a setpoint device enable

Each of the 3 User Buttons can be programmed to enable or disable one or more tN4 setpoint controls on the tN4 bus. The installer programs a setpoint device enable number for one of the User Buttons. In turn, the installer programs a tN4 setpoint control with the same setpoint device enable number. This allows users to enable or disable a tN4 setpoint control by pressing a single button. Multiple tN4 setpoint controls can be enabled or disabled from the same User Switch button.

The tN4 setpoint control operates for the "Occupied Time" or until the User Button is pressed once again to cancel the operation. The User Button is green when the tN4 setpoint control is in operation. Should the tN4 setpoint control be unable to operate, the button turns red for 5 seconds and then the button light is turned off.

See the tN4 Setpoint Control Data Brochure for more information on the setpoint control operation.

Application Examples:

A user can remotely enable a tN4 setpoint control to heat a hot tub or sauna.

A user can remotely enable a tN4 setpoint control to heat a garage or workshop.

3) Disabled Button

The User Button can be disabled so that it does not function when pressed.

In certain cases, the disabled button can be used to close the corresponding relay contact. See the "Button Operation" section for more information.

Programming the User Buttons

STEP 1:

Remove the plastic trim bezel.

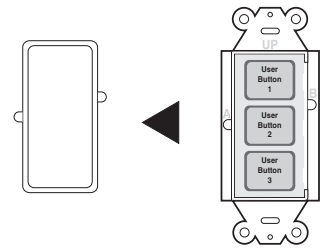

STEP 2:

Press button "A" once using a blunt object to begin programming mode.

Each of the 3 User Buttons will begin to flash to indicate the current program setting:

- Red flashes indicate the User Button is programmed to select a scene. The number of flashes in a row indicate the scene number.
- Green flashes indicate the User Button is programmed to enable or disable a tN4 setpoint control. The number of flashes in a row indicate the setpoint device enable number.
- Orange indicates the User Button has been disabled.

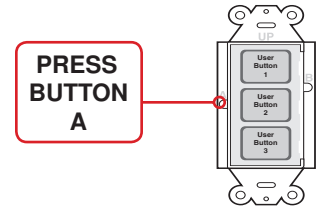

STEP 3:

Press and hold down the User Button until the button changes to the color of operation that is desired and then release the button.

Red = Scene

Green = tN4 Setpoint Control Enable / Disable

Orange = Disabled Button

STEP 4

(Scene Operation, Red Flashes)

Press the User Button the number of times equal to the desired scene.

Press "User" Button	Scene	Red Light Flash Sequence
1 Time	1	1 Red, Off, Repeat
2 Times	2 (Away)	2 Red, Off, Repeat
3 Times	3 (Unoccupied)	3 Red, Off, Repeat
4 Times	4	4 Red, Off, Repeat
5 Times	5	5 Red, Off, Repeat
6 Times	6 (3 hr. Temporary Occupied)	6 Red, Off, Repeat
7 Times	7 (4 hr. Temporary)	7 Red, Off, Repeat
8 Times	8 (8 hr. Temporary)	8 Red, Off, Repeat

STEP 4 (Continued)

(Setpoint Device Enable, Green Flashes)

Press the User Button the number of times equal to the desired setpoint device enable number.

Press "User" Button	Setpoint Enable	Green Light Flash Sequence
1 Time	1	1 Green, Off, Repeat
2 Times	2	2 Green, Off, Repeat
3 Times	3	3 Green, Off, Repeat
4 Times	4	4 Green, Off, Repeat
5 Times	5	5 Green, Off, Repeat
6 Times	6	6 Green, Off, Repeat
7 Times	7	7 Green, Off, Repeat
8 Times	8	8 Green, Off, Repeat
9 Times	9	9 Green, Off, Repeat
10 Times	10	10 Green, Off, Repeat
11 Times	11	11 Green, Off, Repeat
12 Times	12	12 Green, Off, Repeat

STEP 5

Press button "B" to finalize the User Button setting and exit the programming mode.

Note: To return to Step 2 without saving the setting, press button "A".

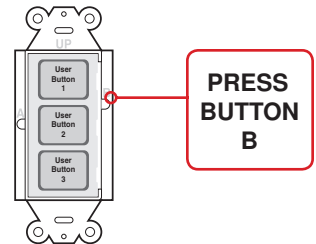

STEP 6

Repeat steps 2 through 5 to program each User Button.

STEP 7

Included with the User Switch are labels to identify the operation of each User Button. Each label has a description on it. Choose the label with the appropriate description for each button.

A template has been included on the back page to create your own labels.

Insert the label into the slot located under the right hand side of each User Button.

Repeat for each User Button.

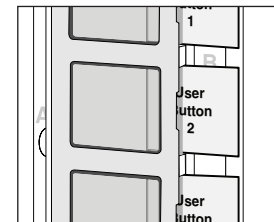

STEP 8

Replace the trim bezel.

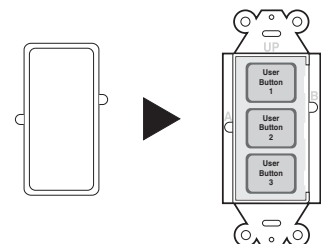

Output Relay Contacts and DIP Switches

The functionality of the 3 dry relay contacts on the User Switch 481 are determined by the settings of DIP switches 1, 2 and 3. Dip switches 1 and 2 select the mode of operation for relay outputs.

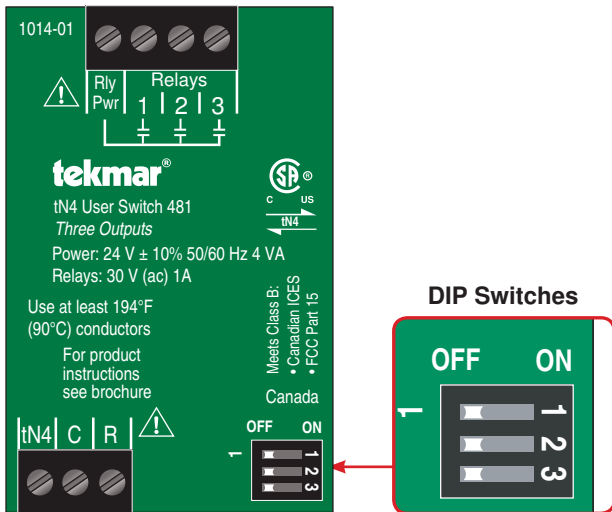

Permanent or Momentary Contact Closure

DIP switch 3 = OFF (Permanent)
DIP switch 3 = ON (Momentary)



The output relay contacts can close momentarily for 5 seconds and then re-open or the relay contacts can close permanently. Use DIP switch 3 to select either Momentary or Permanent. Momentary closure is often used in alarm systems. Permanent is the factory default setting.

Alert and Scene Status

DIP switch 1 = OFF
DIP switch 2 = OFF
DIP switch 3 = Permanent or Momentary



Relay contact 1 closes to provide an alert when there is an error message present on the tN4 system.

Relay contact 2 closes while the scene is set to Away (Scene 2).

Relay contact 3 closes while the scene is set to Scene 3.

Application Examples:

The relay contacts can connect to a third party alarm system or automation system to provide the status of the tN4 system.

Relay contact 2 can connect to a non-tN4 snow melt control (664, 665, 667) to provide an Idle Demand. The snow melt control Idle temperature is set to OFF. While the tN4 system is in Away (scene 2), the snow melt control is prevented from entering the melting operation.

Critical and Non-Critical Alert Levels

DIP switch 1 = ON
DIP switch 2 = OFF
DIP switch 3 = Permanent or Momentary

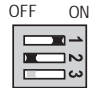

Relay contact 1 closes while a non-critical error message is present on the tN4 system. A non-critical error allows the heating system to continue to operate.

Relay contact 2 closes while a critical error message is present on the tN4 system. A critical error prevents the heating system from operating.

Relay contact 3 is not used.

Application Example:

The relay contacts can connect to a third party paging device that, when activated, pages a service technician when a critical error message is present.

Button Operation

DIP switch 1 = OFF
DIP switch 2 = ON
DIP switch 3 = Permanent or Momentary



Each relay contact is synchronized with the corresponding User Button. When a button is pressed or the scene is changed to the User Button's programmed scene, the relay contact closes.

Application Examples:

The relay contacts can connect to a third party automation system to indicate that one of the User Buttons has been activated.

The User Button can be programmed to the "disabled" button operation. When the User Button is pressed, the light turns green and the corresponding output relay contact can activate lighting, security cameras, alarms or power a melt demand on a non-tN4 snow melt control (664, 665, 667) to manually start snow melting.

Scene Signal

DIP switch 1 = ON
DIP switch 2 = ON
DIP switch 3 = Permanent or Momentary



The relay contacts operate in combinations in order to communicate the current tN4 scene to third party devices. The contacts operate according to the following table:

Scene	1	2	3	4	5	6	7	8
Contact 1	Off	On	Off	On	Off	On	Off	On
Contact 2	Off	Off	On	On	Off	Off	On	On
Contact 3	Off	Off	Off	Off	On	On	On	On

Application Example:

The relay contact can connect to a third party automation system to indicate the current tN4 scene.

Applications using Multiple 480 and 481 Together

Multiple User Switches 480 and 481 can be used together when:

- 1) Applications require more than 3 User Buttons.
- 2) Applications require both input demands and output relay contacts.
- 3) User Switches with the same functionality are required at different locations.

Each tN4 bus cannot exceed 24 devices. Devices include Thermostats, Setpoint Controls, Mixing Expansion Modules, and User Switches.

When using multiple User Switches at the same location, they can be installed adjacent to each other in the same switch box.

Applications requiring more than 3 User Buttons

When more than 3 User Buttons are required, two or more User Switches can be located next to each other in a double switch box. Each button can be programmed to either select a scene or provide a setpoint enable.

Application Example:

Applications that select more than three scenes or setpoint device enables will require two or more User Switches.

Applications with both input demands and output relay contacts

Applications that require input demands and output relay contacts require a 480 and a 481. The 480 provides the input demands and the 481 provides the output contacts.

Application Example:

A third party telephone switch device allows a user to change the scene from 1 to 2 (Away) through the demand input on the 480. Should a critical or non-critical error occur on the tN4 system, a 481 can close an alert contact to allow a third party telephone switch to page a service technician.

User Switches with the same functionality at different locations

There may be applications where there are two or more User Switches installed in a building. Each of the User Switch User Buttons can be programmed with the same functionality. When an User Button is pressed, User Buttons with the same functionality will all light green at the same time.

Application Example:

A User Switch is installed in the garage and another User Switch is installed in the master bedroom.

Error Messages & Troubleshooting

Error Messages

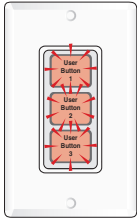
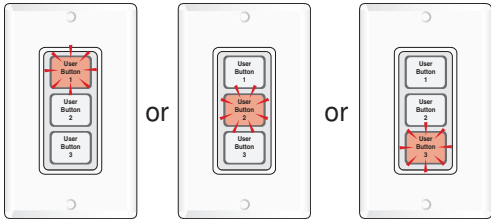
Symptom	Cause	Corrective Action
<p>3 Buttons Flashing Red</p> 	<p>User Switch disconnected from tN4 bus.</p>	<ul style="list-style-type: none"> • Check tN4 and common wires for loose wire connections. • Ensure the tN4 controls have power. • Check R and C wires for correct polarity.
<p>1 Button Flashing Red</p> 	<p>The User Button is configured for setpoint device enable operation and there is no response from the tN4 setpoint control.</p>	<ul style="list-style-type: none"> • Ensure the setpoint device has power and is connected to the tN4 bus. • Ensure the setpoint device enable number of the User Button and of the tN4 setpoint control match.

Cleaning the User Switch

The User Switch's exterior can be cleaned using a damp cloth. Moisten the cloth with water and wring out prior to wiping the device. Do not use solvents or cleaning solutions.

User Button Label Template

1. Download the User Switch Data Brochure PDF file D481.pdf from the Downloadable Literature Section on our tekmar website: <http://www.tekmarcontrols.com> to your computer.
2. Click on the grey area (text field) and type the label description.
3. Print this page onto transparency film. Ensure the correct transparency film type is used for either laser printers or bubble-jet printers.

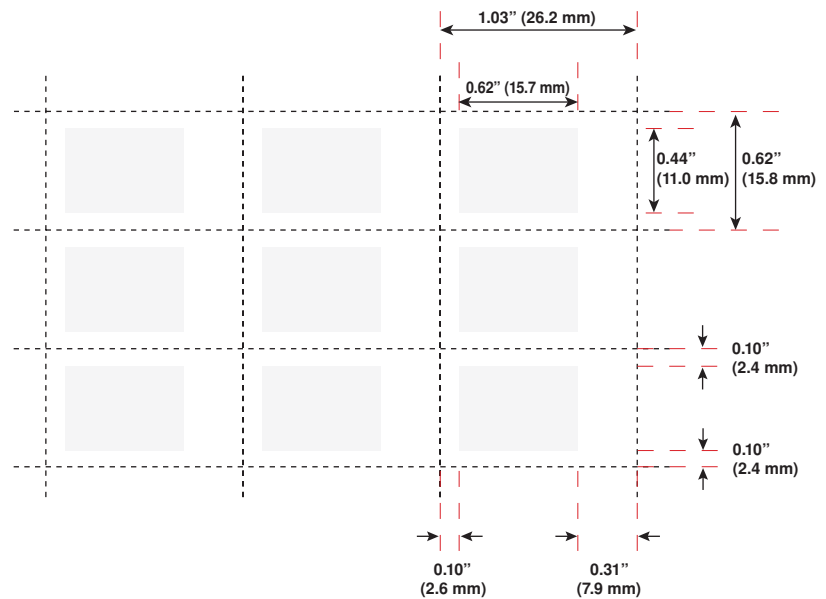

Limited Warranty and Product Return Procedure

Limited Warranty *The liability of tekmar under this warranty is limited. The Purchaser, by taking receipt of any tekmar product ("Product"), acknowledges the terms of the Limited Warranty in effect at the time of such Product sale and acknowledges that it has read and understands same.*

The tekmar Limited Warranty to the Purchaser on the Products sold hereunder is a manufacturer's pass-through warranty which the Purchaser is authorized to pass through to its customers. Under the Limited Warranty, each tekmar Product is warranted against defects in workmanship and materials if the Product is installed and used in compliance with tekmar's instructions, ordinary wear and tear excepted. The pass-through warranty period is for a period of twenty-four (24) months from the production date if the Product is not installed during that period, or twelve (12) months from the documented date of installation if installed within twenty-four (24) months from the production date.

The liability of tekmar under the Limited Warranty shall be limited to, at tekmar's sole discretion: the cost of parts and labor provided by tekmar to repair defects in materials and/or workmanship of the defective product; or to the exchange of the defective product for a warranty replacement product; or to the granting of credit limited to the original cost of the defective product, and such repair, exchange or credit shall be the sole remedy available from tekmar, and, without limiting the foregoing in any way, tekmar is not responsible, in contract, tort or strict product liability, for any other losses, costs, expenses, inconveniences, or damages, whether direct, indirect, special, secondary, incidental or consequential, arising from ownership or use of the product, or from defects in workmanship or materials, including any liability for fundamental breach of contract.

The pass-through Limited Warranty applies only to those defective Products returned to tekmar during the warranty period. This Limited Warranty does not cover the cost of the parts or labor to remove or transport the defective Product, or to reinstall the repaired or replacement Product, all such costs and expenses being subject to Purchaser's agreement and warranty with its customers.

Any representations or warranties about the Products made by Purchaser to its customers which are different from or in excess of the tekmar Limited Warranty

are the Purchaser's sole responsibility and obligation. Purchaser shall indemnify and hold tekmar harmless from and against any and all claims, liabilities and damages of any kind or nature which arise out of or are related to any such representations or warranties by Purchaser to its customers.

The pass-through Limited Warranty does not apply if the returned Product has been damaged by negligence by persons other than tekmar, accident, fire, Act of God, abuse or misuse; or has been damaged by modifications, alterations or attachments made subsequent to purchase which have not been authorized by tekmar; or if the Product was not installed in compliance with tekmar's instructions and/or the local codes and ordinances; or if due to defective installation of the Product; or if the Product was not used in compliance with tekmar's instructions.

THIS WARRANTY IS IN LIEU OF ALL OTHER WARRANTIES, EXPRESS OR IMPLIED, WHICH THE GOVERNING LAW ALLOWS PARTIES TO CONTRACTUALLY EXCLUDE, INCLUDING, WITHOUT LIMITATION, IMPLIED WARRANTIES OF MERCHANTABILITY AND FITNESS FOR A PARTICULAR PURPOSE, DURABILITY OR DESCRIPTION OF THE PRODUCT, ITS NON-INFRINGEMENT OF ANY RELEVANT PATENTS OR TRADEMARKS, AND ITS COMPLIANCE WITH OR NON-VIOLATION OF ANY APPLICABLE ENVIRONMENTAL, HEALTH OR SAFETY LEGISLATION; THE TERM OF ANY OTHER WARRANTY NOT HEREBY CONTRACTUALLY EXCLUDED IS LIMITED SUCH THAT IT SHALL NOT EXTEND BEYOND TWENTY-FOUR (24) MONTHS FROM THE PRODUCTION DATE, TO THE EXTENT THAT SUCH LIMITATION IS ALLOWED BY THE GOVERNING LAW.

Product Warranty Return Procedure All Products that are believed to have defects in workmanship or materials must be returned, together with a written description of the defect, to the tekmar Representative assigned to the territory in which such Product is located. If tekmar receives an inquiry from someone other than a tekmar Representative, including an inquiry from Purchaser (if not a tekmar Representative) or Purchaser's customers, regarding a potential warranty claim, tekmar's sole obligation shall be to provide the address and other contact information regarding the appropriate Representative.



tekmar Control Systems Ltd., Canada
tekmar Control Systems, Inc., U.S.A.
Head Office: 5100 Silver Star Road
Vernon, B.C. Canada V1B 3K4
(250) 545-7749 Fax. (250) 545-0650
Web Site: www.tekmarcontrols.com

